

JVT2512T

The ring terminal

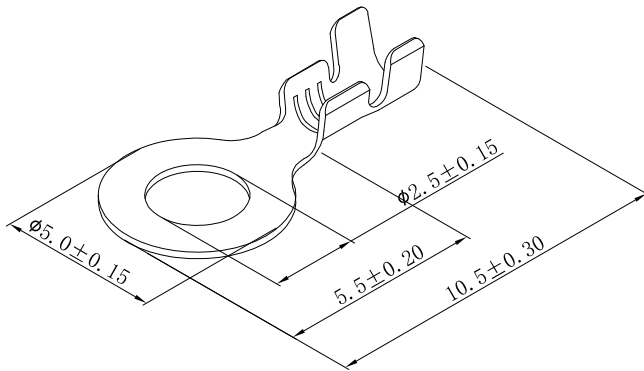

JVT2512TB-SNS
Logo
Series NO.
T-Terminal
Brass
S-Stamping before Plating
SN-Tin Plated

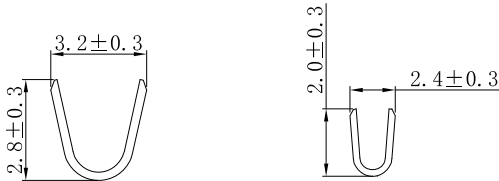

JVT2512TB-SNS	Brass	Tin-plated	22-24# AWG	2.10mmMAX	0.25mm
PART NO	Material	Finish(Pin)	Wire Range	Insulation O.D.	Thickness

JVT3200T

The ring terminal

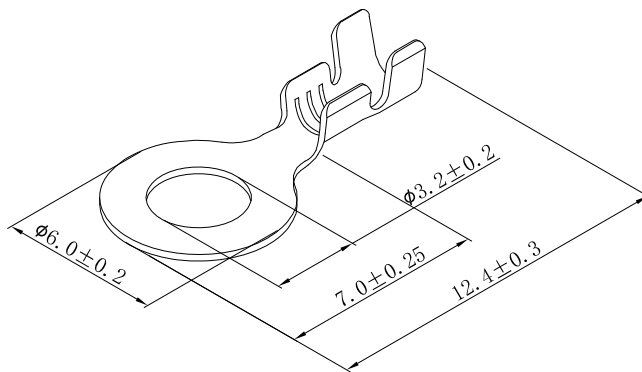

JVT3200TB-XXX
Logo
Series NO.
T-Terminal
Brass
S-Stamping before Plating
E-First after plating
SN-Tin Plated
SW-Fog tin Plated

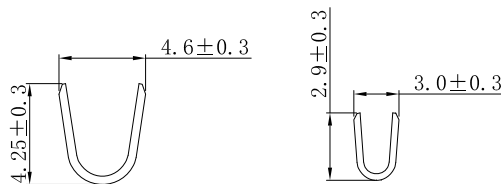

JVT3200TB-XXX	Brass	Tin-plated/ Fog tin plated	16AWG-18AWG	3.10mmMAX	0.35mm
PART NO	Material	Finish(Pin)	Wire Range	Insulation O.D.	Thickness

JVT4300T

The ring terminal

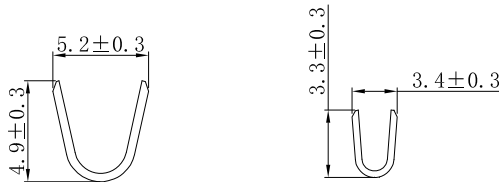
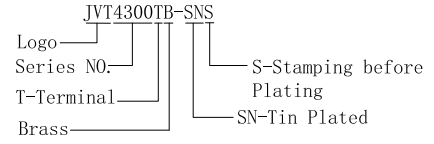
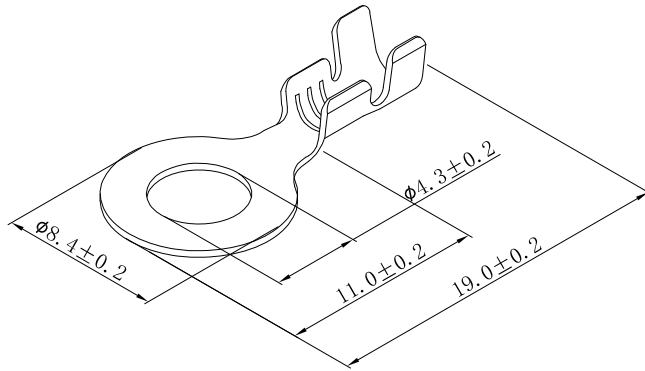

JVT4300TB-SNS	Brass	Tin-plated	NA	NA	0.50mm
PART NO	Material	Finish(Pin)	Wire Range	Insulation O.D.	Thickness

JVT4379T

The ring terminal

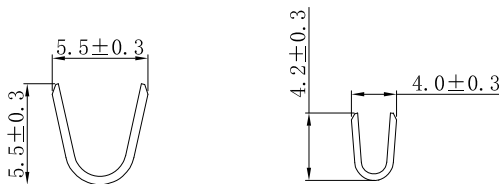
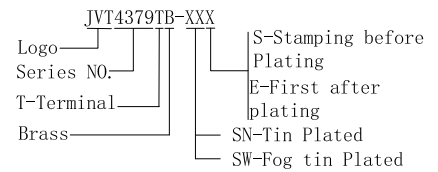
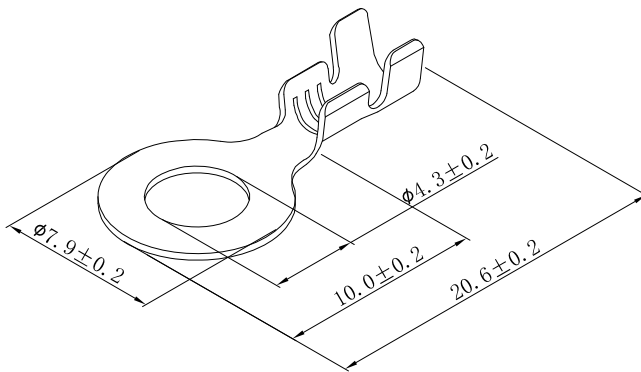

JVT4379TB-XXX	Brass	Tin-plated/ Fog tin plated	NA	NA	0.50mm
PART NO	Material	Finish(Pin)	Wire Range	Insulation O.D.	Thickness

JVT6310T

The ring terminal

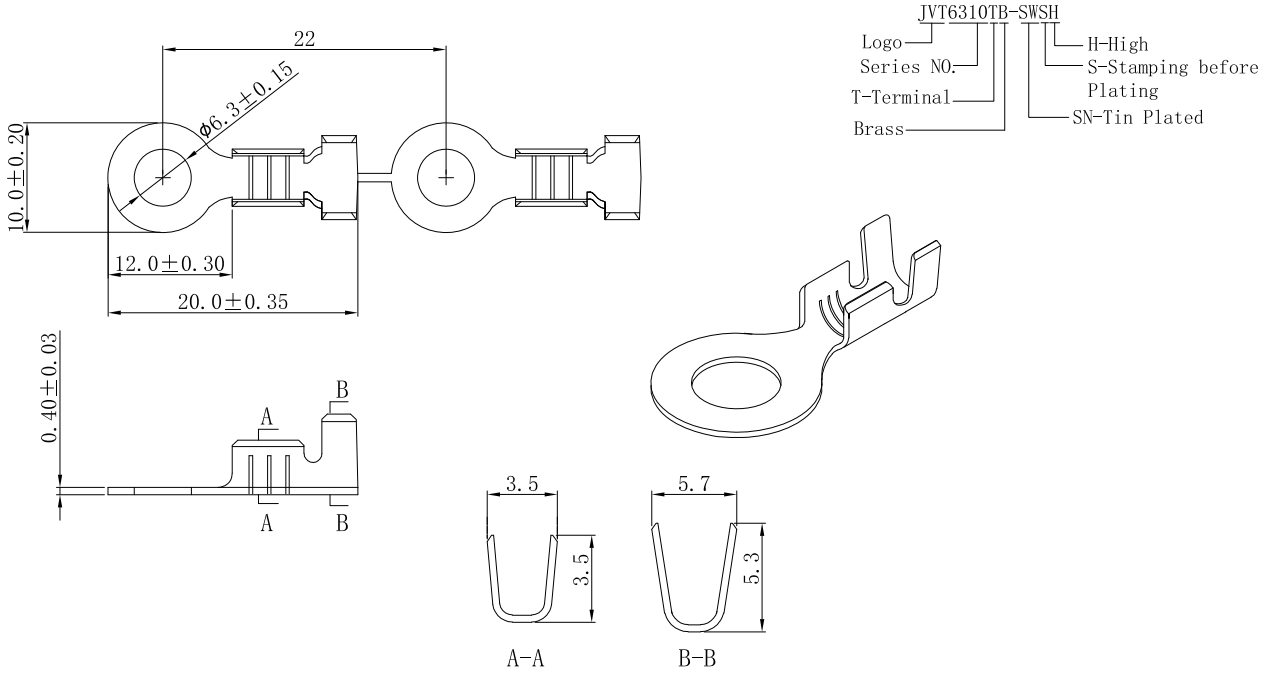

JVT6310TB-SWSH	Brass	Tin-plated	16-20#	NA	0.40mm
PART NO	Material	Finish(Pin)	Wire Range	Insulation O.D.	Thickness

JVT6310T

The ring terminal

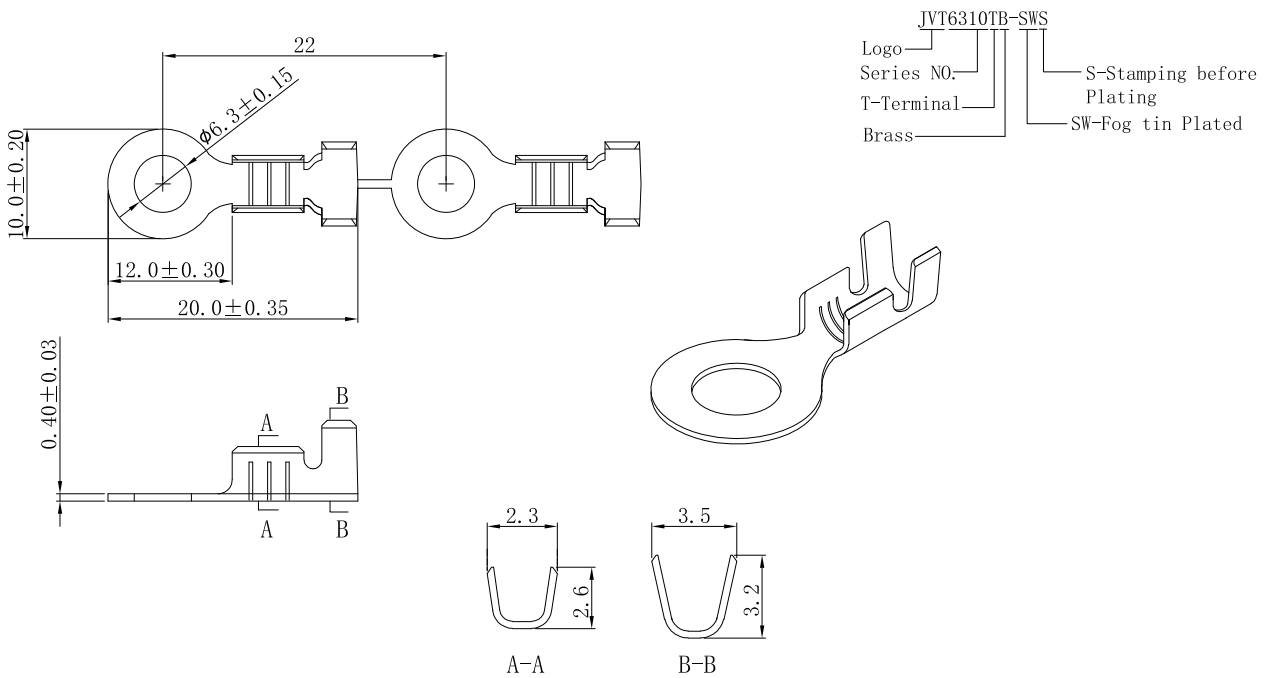

JVT6310TB-SWS	Brass	Fog tin plated	20-24#	NA	0.40mm
PART NO	Material	Finish(Pin)	Wire Range	Insulation O.D.	Thickness

JVT3880 SERIES

The ring terminal

JVT3880T

The ring terminal

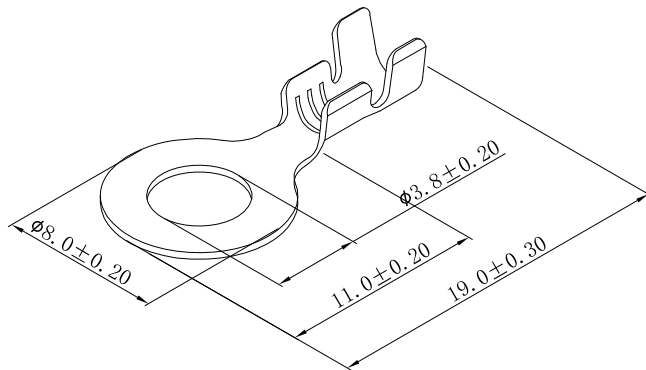

JVT3880TB-SNS
Logo
Series NO.
T-Terminal
B-Brass
S-Stamping before Plating
SN-Tin Plated

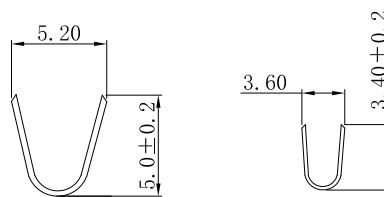

JVT3880TB-SNS	Brass	Tin-plated	16~20#	NA	0.50mm
PART NO	Material	Finish(Pin)	Wire Range	Insulation O. D.	Thickness

JVT5380T

The ring terminal

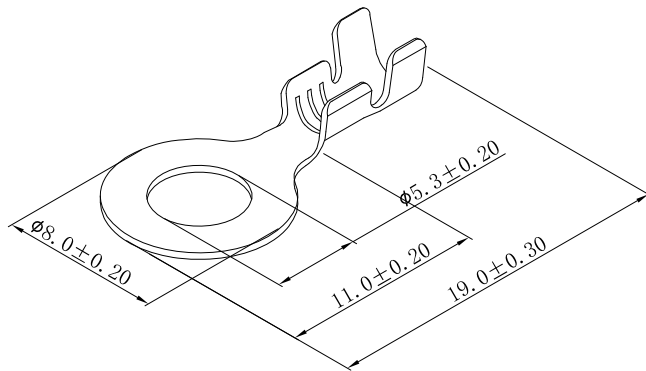

JVT5380TB-SNS
Logo
Series NO.
T-Terminal
B-Brass
S-Stamping before Plating
SN-Tin Plated

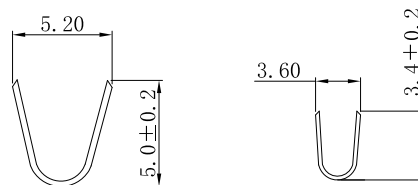

JVT5380TB-SNS	Brass	Tin-plated	16~20#	NA	0.50mm
PART NO	Material	Finish(Pin)	Wire Range	Insulation O. D.	Thickness

JVT8040 SERIES

The ring terminal

JVT8040T

The ring terminal

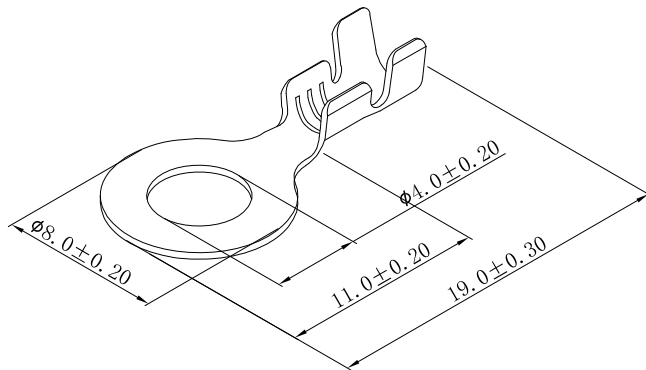

JVT8040TB-SNS
Logo
Series NO.
T-Terminal
B-Brass
S-Stamping before Plating
SN-Tin Plated

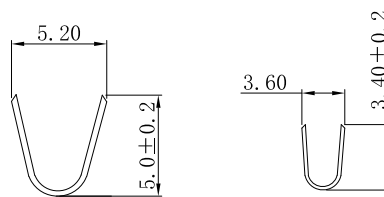

JVT8040TB-SNS	Brass	Tin-plated	16~20#	NA	0.50mm
PART NO	Material	Finish(Pin)	Wire Range	Insulation O. D.	Thickness

JVT5384T

The ring terminal

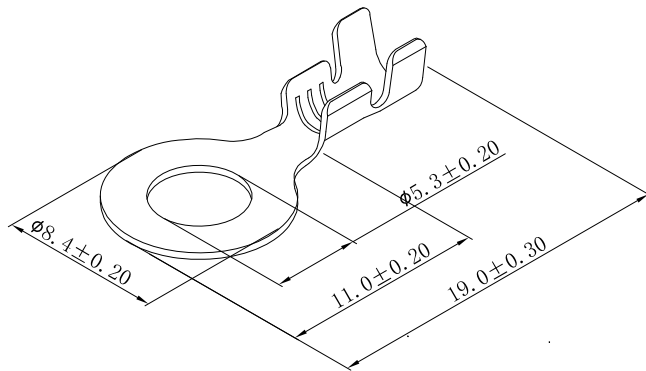

JVT5384TB-SNS
Logo
Series NO.
T-Terminal
B-Brass
S-Stamping before Plating
SN-Tin Plated

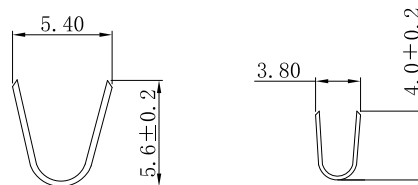

JVT5384TB-SNS	Brass	Tin-plated	16~20#	NA	0.50mm
PART NO	Material	Finish(Pin)	Wire Range	Insulation O. D.	Thickness

JVT2850 SERIES

The ring terminal

JVT2850T

The ring terminal

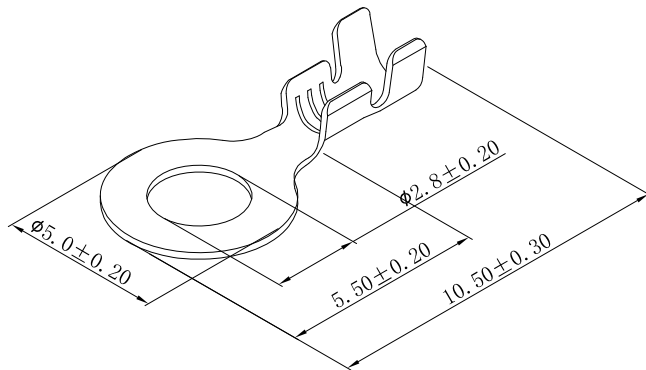

JVT2850TB-SNS
Logo
Series NO.
T-Terminal
B-Brass
S-Stamping before Plating
SN-Tin Plated

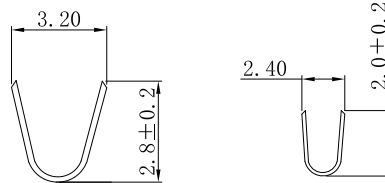

JVT2850TB-SNS	Brass	Tin-plated	16~20#	NA	0.40mm
PART NO	Material	Finish(Pin)	Wire Range	Insulation O. D.	Thickness

JVT4384T

The ring terminal

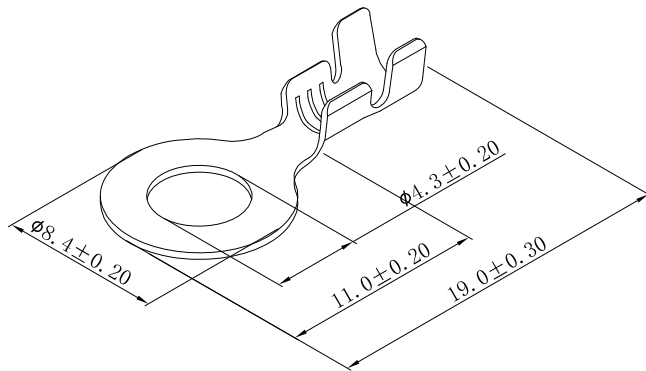

JVT4384TB-SNS
Logo
Series NO.
T-Terminal
B-Brass
S-Stamping before Plating
SN-Tin Plated

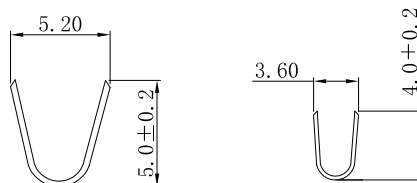

JVT4384TB-SNS	Brass	Tin-plated	16~20#	NA	0.50mm
PART NO	Material	Finish(Pin)	Wire Range	Insulation O. D.	Thickness

JVT3250 SERIES

The ring terminal

JVT3250T

The ring terminal

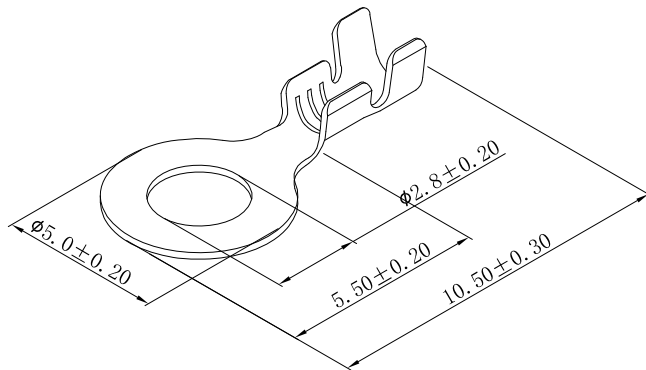

JVT3250TB-SNS
Logo
Series NO.
T-Terminal
B-Brass
S-Stamping before Plating
SN-Tin Plated

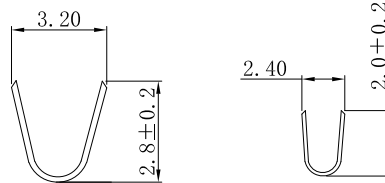

JVT3250TB-SNS	Brass	Tin-plated	16~20#	NA	0.40mm
PART NO	Material	Finish (Pin)	Wire Range	Insulation O. D.	Thickness

JVT3580T

The ring terminal

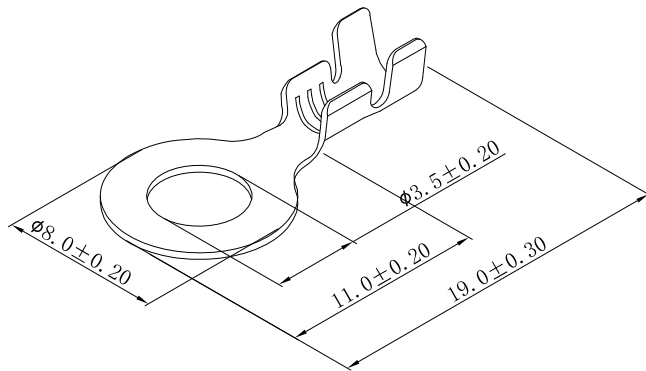

JVT3580TB-SNS
Logo
Series NO.
T-Terminal
B-Brass
S-Stamping before Plating
SN-Tin Plated

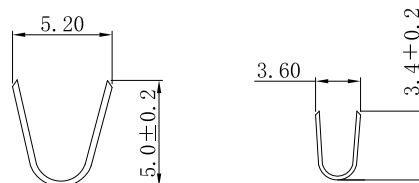

JVT3580TB-SNS	Brass	Tin-plated	16~20#	NA	0.50mm
PART NO	Material	Finish (Pin)	Wire Range	Insulation O. D.	Thickness