

JVT1628T

1628 Soldering terminal

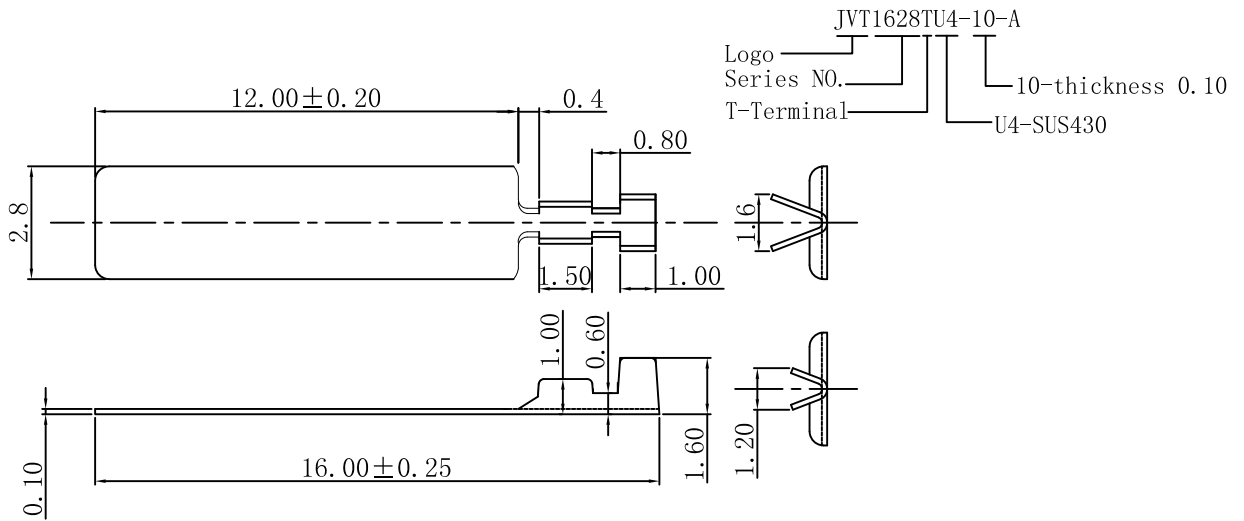

JVT1628TU4-10-A	SUS430	NA	28AWG-32AWG	0.8mm MAX	NA
PART NO	Material	Finish(Pin)	Wire Range	Insulation O.D.	Mates With Part(s)

JVT1628T

1628 Soldering terminal

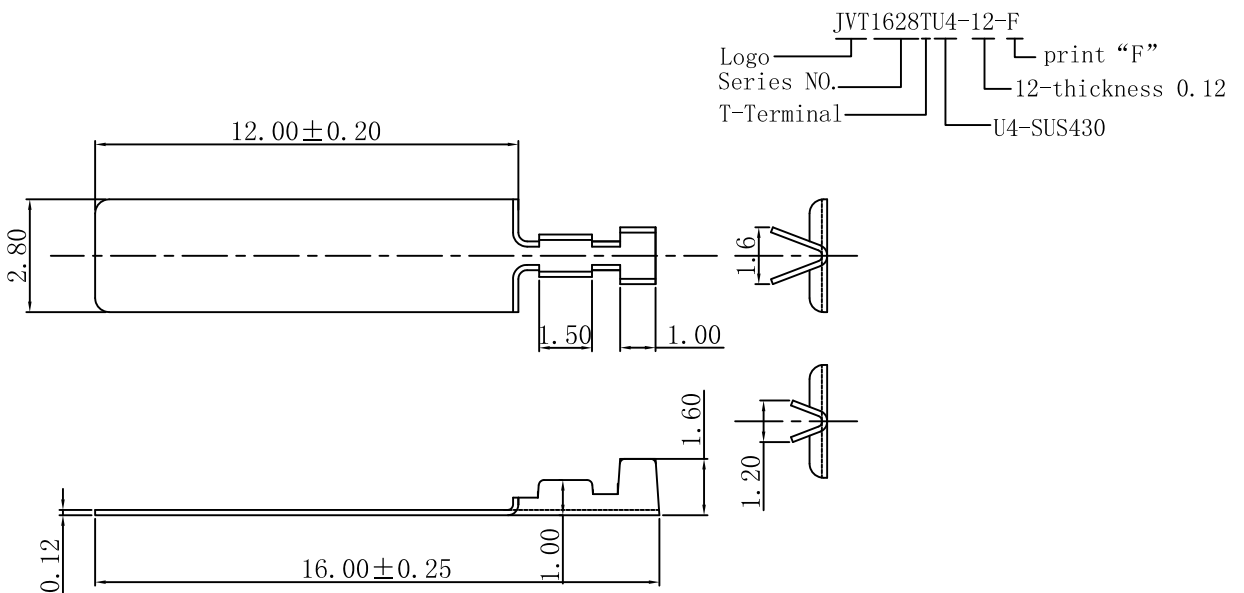

JVT1628TU4-10-A	SUS430	NA	28AWG-32AWG	0.8mm MAX	NA
PART NO	Material	Finish(Pin)	Wire Range	Insulation O.D.	Mates With Part(s)

JVT1632T — 1632 Soldering terminal

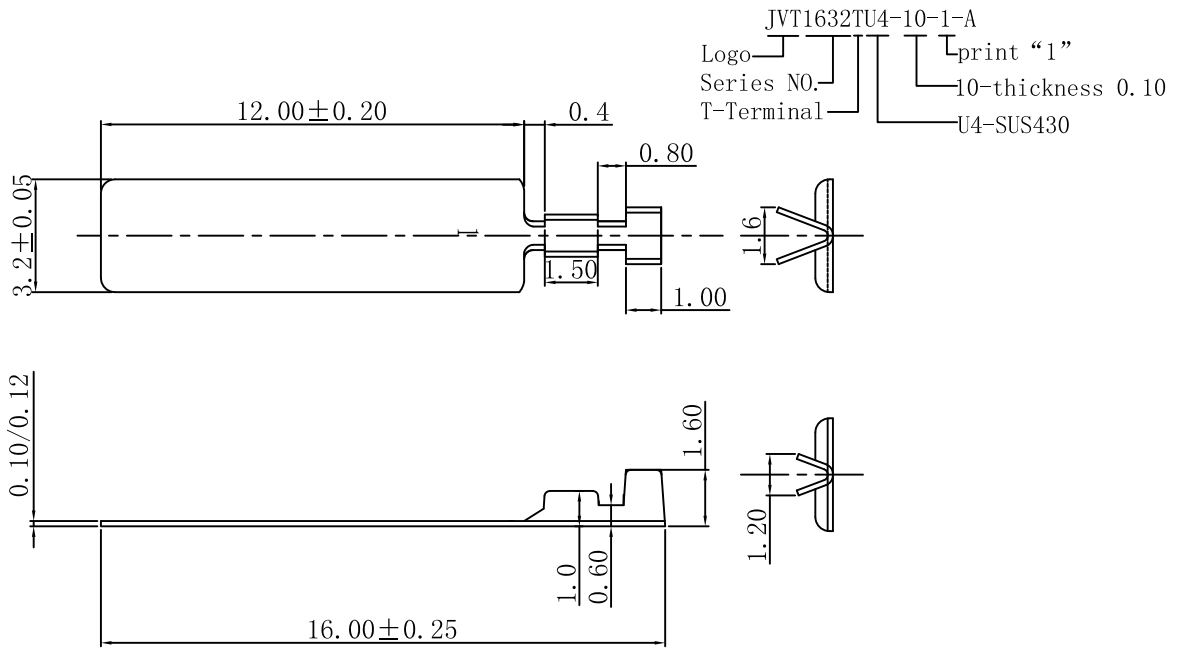

JVT1632TU4-10-1-A	SUS430	NA	28AWG-32AWG	0.8mm MAX	NA
PART NO	Material	Finish(Pin)	Wire Range	Insulation O.D.	Mates With Part(s)

JVT1632T — 1632 Soldering terminal

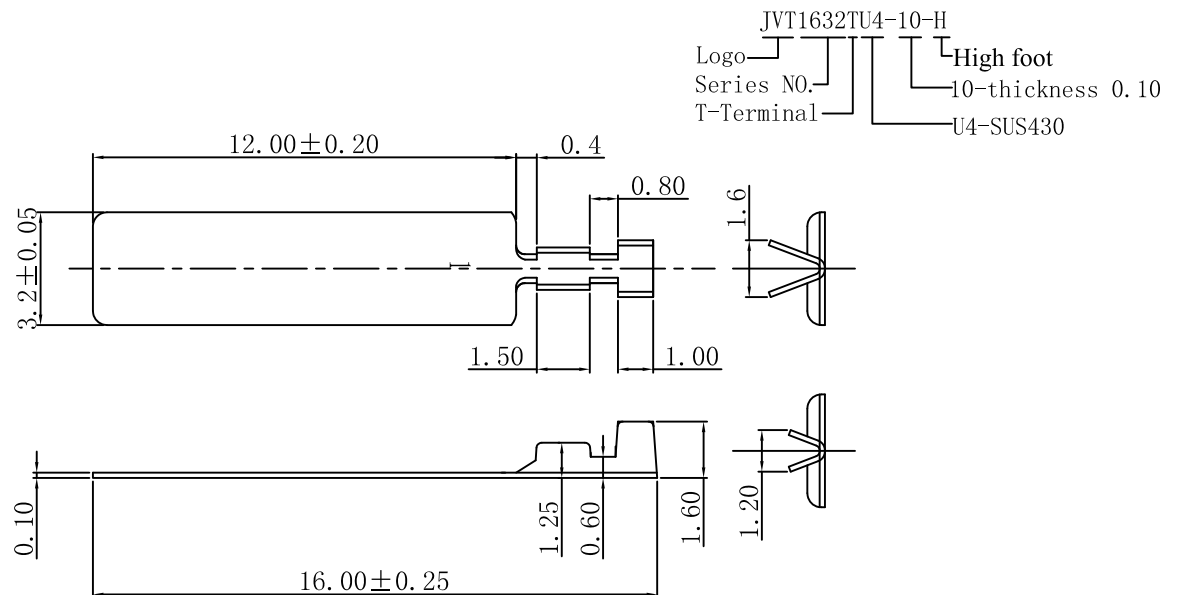

JVT1632TU4-10-H	SUS430	NA	28AWG-32AWG	0.8mm MAX	NA
PART NO	Material	Finish(Pin)	Wire Range	Insulation O.D.	Mates With Part(s)